

Atlas Copco Exploration Products

Diamec™ core drilling rigs



Atlas Copco

Diamec core drilling rigs – the latest in exploration technology

Atlas Copco is probably the most experienced core drilling company on the market today. Our expertise and innovative solutions have helped companies worldwide to mine profitably. Today, it's becoming more and more viable to drill deeper for minerals, and with it the need to find ore with a minimum of excavation. That's why drilling deeper and larger exploration holes with bigger core samples is enjoying a surge in popularity. The Diamec™ range of drill rigs offers just the user-friendly solutions needed, along with the latest in exploration technology and productivity.

At home above or below ground

The compact size of the Diamec rigs enables them to move in tight spaces with minimum disturbance. This makes them ideal for underground exploration. But it's the modularized system of rig, power unit, flushing pumps and control podium that also makes these rigs popular in surface operations. Moving the rigs to isolated sites is much easier.

A comprehensive range of exploration rigs

The Diamec range comprises five exploration rigs. The smallest, the Diamec 232, is designed for short holes up to 120 m deep. The latest edition is the Diamec U4 for drilling holes up to 500 m. The Diamec U6 is available in two versions – a standard version and a deep hole version for holes up to 1 000 m. Finally, you'll find the Diamec U8 for holes up to 2 000 m deep at the top of the range.

Meeting customer needs

The Diamec range of core drill rigs can be operated in a multitude of applications. They can be used above or below ground, in traditional core drilling and in special applications such as salt mines or even coal mines. And thanks to the choice of feed frames and rotation units the rig can be adapted to customers needs.





Moving into position

While it's easy set up these rigs and move them into place with the standard skid-chassis, the unique optional Atlas Copco crawler system makes light work of the larger rigs. This powered crawler moves the rig into place without the aid of any other vehicle. And all the modules are mounted on-board, keeping dirt and dust at bay.

Drill in any direction

As the size and height of drill sites vary, Diamec rigs are equipped with standard feed frames of 1 800 mm, while a short version of 850 mm is available for tighter sites. Whether you want to drill vertically upwards, downwards or horizontally, Diamec rigs solve your problem. With just one operator at the controls, the unique positioner arm moves the feeder frame to the angle of your choice, facilitating a new drilling position quickly and easily.

Making work easier

At Atlas Copco we make our rigs as user-friendly as possible. Based on our experience of underground drifting



rigs, the Automatic Performance Control system (APC) helps increase drilling productivity. Thanks to APC, all the operator needs to do is set the drilling parameters – the rest is done automatically. This unique option means maximum rig performance and service life of the in-the-hole, (ITH) equipment – and more time to work, for example, with the core samples.

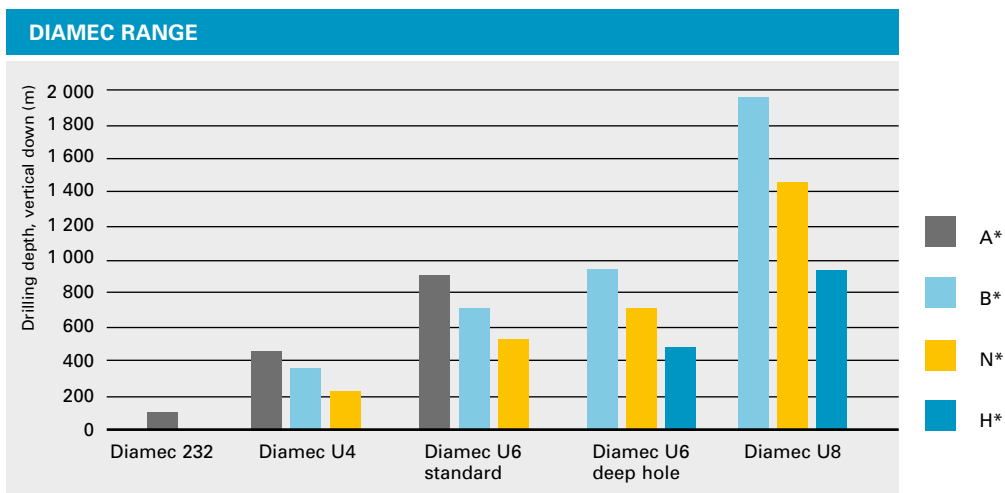

* Hole dimensions; DCDMA std

Diamec 232 – tried and tested

Basic data

Max depth	120 m (400 ft) (A)
Diameter	50 mm (2")
Max speed	2 200 rpm
Max torque	250 Nm (180 lbf ft)
Feed force	20 kN (4 500 lbf)
Pull force	15 kN (3 400 lbf)
Feed length	850 mm (33 ¹ / ₂ ")

Modules

Flush pump	Trido 45
Power unit*	PU 20E or PU 20D

* Electric (E) or diesel (D)



The smallest member of the range is Diamec 232 – a tried and tested rugged model that's ideal for short hole core drilling. The A-size ITH tools facilitate holes up to 120 m in depth with excellent core quality. The standard skid allows the rig to be moved with a minimum of effort – and without disturbing other operations in the mine.



Diamec U4 – the latest member of the range

Basic data

Max depth	500 m (1 650 ft) (A)
Diameter	78 mm (3 1/16")
Max speed*	1 800 rpm
Max torque*	660 Nm (490 lbf ft)
Feed/Pull force	52 kN (11 700 lbf)
Feed lengths	850 mm (33 1/2") or 1 800 mm (70")

Modules

Flush pump	Trido 80
Power unit**	PU 45E or PU 40DT

Hydraulic control systems

- Direct hydraulic control
- APC, Automatic performance control

* Also available as high torque

** Electric (E) or diesel (DT)



Diamec U4, our most recent addition to the range, is based on the tried and tested Diamec U6 rig. It's very compact and powerful for its size and easy to set up. Ideal for both underground and surface drilling, it can be equipped with a long or short feed frame and wire line equipment. The push-equals-pull feed cylinder also allows for maximum capacity uphole and downhole drilling. Diamec U4 is ideal for both conventional and wire line drilling and using A-sized ITH tools it reaches as deep as 500 meters.



Diamec U6 and U6DH – reaching down to 1 000 m

Basic data

	U6 Standard	U6DH (deep hole)
Max depth	960 m (3 200 ft) (A)	1 000 m (3 300 ft) (B)
Diameter	100 mm (4")	100 mm (4")
Max speed*	1 800 rpm	1 400 rpm
Max torque*	700 Nm (515 lbf ft)	1 375 Nm (1 020 lbf ft)
Feed/Pull force	65 kN (14 600 lbf)	89 kN (20 000 lbf)
Feed lengths	850 mm (33 1/2") or 1 800 mm (70")	1 800 mm (70")

Modules

Flush pump	Trido 80	Trido 140
Power unit**	PU 55E or PU 100DT	PU 75E or PU 100DT

Hydraulic control systems

- PHC, Pilot hydraulic control
- APC, Automatic performance control

* Also available as high torque

** Electric (E) or diesel (DT)



Diamec U6 is a truly flexible exploration rig, drilling up to 1 000 m with both A-size and B-size ITH tools. (The later, thanks to the Diamec U6DH's more powerful feed cylinder.)

They are both at home in underground and surface exploration. There's also a wide choice of equipment available, including two feed frames, four rotation units, two chassis models and two types

of control systems. This powerful and compact rig has become very popular amongst those wanting to drill deep and large holes.

The unique positioner allows you to move the feed frame through 180°. The operator won't need any help setting up the right drilling angle – be it vertical, horizontal or in between.



Diamec U8 – topping the range at 2 000 m

Basic data

Max depth	2 000 m (6 600 ft) (B)
Diameter	100 mm (4")
Max speed	1 200 rpm
Max torque	2 300 Nm (1 630 lbf ft)
Feed/Pull force	133 kN (29 000 lbf)
Feed lengths	1 800 mm (70")

Modules

Flush pump	Trido 140
Power unit*	PU 110E or PU 160DT

Hydraulic control systems

- PHC, Pilot hydraulic control
- APC, Automatic performance control

* *Electric (E) or diesel (DT)*



The Diamec U8 is a true deep hole exploration rig. It's quite simply the most powerful exploration rig for its size on the market today. At home both above and below ground, the Diamec U8 can drill up to 2 000 m.

Frequently operating for weeks on end with the same bore hole, it's imperative that the rig keeps running efficiently. Here's where the Automatic Performance System (APC)* comes into its own. All the operator needs to do is set the drilling parameters and the APC* takes care of the rest. No other surface core drill rig can offer this level of automation.

*optional equipment



Automatic Performance Control (APC) – a computerized rig supervisor

Every rig owner's aim is to drill as fast as possible, at the lowest possible cost. That's why Atlas Copco developed the Automatic Performance Control system. In fact, the optional APC is rapidly transforming U4, U6 and U8 Diamec rigs into the one-man operation you've been looking for!



Your drilling supervisor

With APC, the drilling operation is supervised by a computer. Once you've entered the key parameters, the APC computer assumes control in order to maintain a constant penetration rate. The system reacts instantly to the slightest change in rock formation, adjusting feed force, or torque accordingly. It can even shut down the rig if necessary.

A real one-man operation

Whether it's a Diamec U4, U6 or U8, one operator on the job is enough. In fact, this system is so user-friendly that both experienced and less experienced drillers can get the best out of a Diamec rig. And while the rig handles the drilling, the operator can check the

core samples or carry out other maintenance work. APC provides efficient rod handling, improved bit life, less core blockage and minimum deviation. Not to mention fewer human errors.

Touch screen computer

APC uses the latest in computer technology. Based on Atlas Copco's field-proven RCS-technology, APC is the most user-friendly and efficient system on the market today. All relevant information is displayed on a touch screen that enables the selection of the right parameters. There's a separate menu for drilling, rod running and wire line operation. What's more, there's a built-in operator's manual and – if need be – a manual override.



All the operating data is saved and diagnosed, or can be downloaded onto a USB memory stick for future analysis by external computers.



Unique features that make the difference*



Feed frame



Rotation unit



Rodholder

Feed frame

The feed frame is the backbone of the drill rig. This robust system uses a direct feed cylinder with “push-equals-pull” characteristics. This means the rig can drill uphole just as easily as downhole while having better control of the drilling process. It also facilitates rod handling. There are no chains, sprockets or shafts that need adjusting and self-centering slide shoes ensure straighter holes.

To up safety, the feed frame is equipped with a special guard that prevents anything from getting in the way of the moving parts.

Rod holder

Placed at the base of the feed frame, the rod holder uses the latest in gas spring technology. A gas cartridge ensures high clamping force while the machine’s hydraulics open the holder. This safety measure means the rod is

always clamped in place when the rig is shutdown. This extremely reliable holder has a seal life of 1 000 000 cycles and is easily serviced or replaced. For extra safety, the gas pressure is monitored from the rig’s control panel. Furthermore, as it features fewer parts than competing systems, you’re looking at a lot less maintenance.

Rotation unit

These units are the muscles of the rig. Depending on the size and application of the rigs, there’s a unit to fit the job. Each model is designed with oversized bearings to increase reliability. The gear case is thoroughly sealed to handle

drilling from +90° to -90° angles. And the Atlas Copco patented hydraulic chuck with quick-change jaws facilitates both superior rod grip and fast rod changes.

Flush pumps

Atlas Copco opts for Trido flush pumps for Diamec rigs. These robust, well-dimensioned pumps make sure the right amount of water is pumped into the hole at the right pressure. It also facilitates cuttings removal, cooling and stabilization of the hole. Diesel, hydraulic and electrically powered models available - depending on your needs.



Flush pump

* for Diamec U4, U6 and U8 models only



Positioner

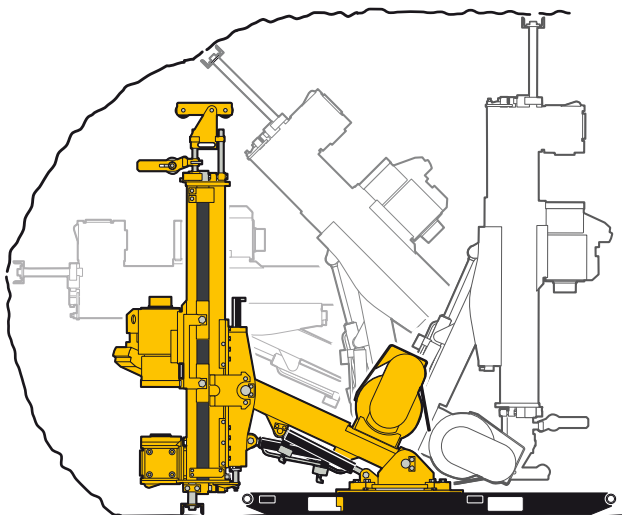

Easily adjusted from -90° to +90° thanks to the positioner

Positioner

Only available on the Diamec U4 and U6, this unique positioner system facilitates movement of the feed frame through 180°. With the aid of levers, the synchronized dual hydraulic cylinders move the feed frame from vertically downwards all the way up to vertically upwards – and there's no need to move the wire line winch. This ingenious device ensures exact lining up to existing holes.

A turntable is also available for easier horizontal adjustment on the Diamec U4 and U6 models.

Power units

Atlas Copco offers electrical or diesel driven power units, depending upon the type of site. In general, Diamec rigs use a dual hydraulic pump system, a main pump and a service pump. These two pumps split the supply of power to the various hydraulic units thus optimizing performance. They are also generously dimensioned. The Diamec U8 is equipped with a triple-pump power unit.

Sustainable, safe and user-friendly

Atlas Copco is committed to environmental sustainability. This has been shown in our efforts over the years to make core drill rigs and equipment as safe and user-friendly as possible without causing detrimental effects on the environment. In fact, today we surpass the rigorous standards laid down by the European safety organization, CE. For example all our rigs are equipped with a feed frame guard as standard that helps to minimize the risk of accidents for the operator.



Power unit



In-the-hole tools for efficient production

Atlas Copco is one of the largest suppliers of in-the-hole tools on the market today. With more than 100 years of experience in diamond core drilling, we boast one of the best selections of top quality diamond core bits, core barrels and drill rods.

Diamond drill bits

Atlas Copco has dedicated years to developing and manufacturing exploration core bit designs (we were first with the impregnated diamond bit). In fact, we're confident our broad range of tried and tested bit designs will meet your needs – irrespective of rock conditions.

We offer impregnated diamond bits; surface set bits; tungsten carbide or TC bits and PDC or poly-crystalline diamond composite bits.

These are available from sizes A to S (46-146 mm in diameter) and operate in everything from soft, unconsolidated to extremely hard and abrasive rock conditions.

Core barrels

Retrieving superior core samples is the very essence of the drilling operation. That's why we have a full range of wire line and conventional core barrels in the most commonly used designs.

Exploration drill rods

Our standard conventional friction welded and wire line drill rods are manufactured from high quality steel. This ensures excellent abrasive resistance and long service life.

Lightweight composite and aluminum drill rod systems are also available for deep hole conventional core drilling.





Atlas Copco Geotechnical Drilling and Exploration
www.atlascopco.com

6991 1517 01a Mårsta, Sweden, January, 2008

© Copyright 2008, Atlas Copco Craelius AB, Mårsta, Sweden. Any unauthorized use or copying of the contents or any part thereof is prohibited. This applies in particular to trademarks, model denominations, part numbers and drawings. Illustrations and photos in this brochure may show equipment with optional extras. Specifications and equipment subjects to change without notice. Consult your Atlas Copco Customer Center for specific information.