

Boomer M2 D Sp

Equipped with COP 1638, COP 1838ME or COP 2238 rock drills

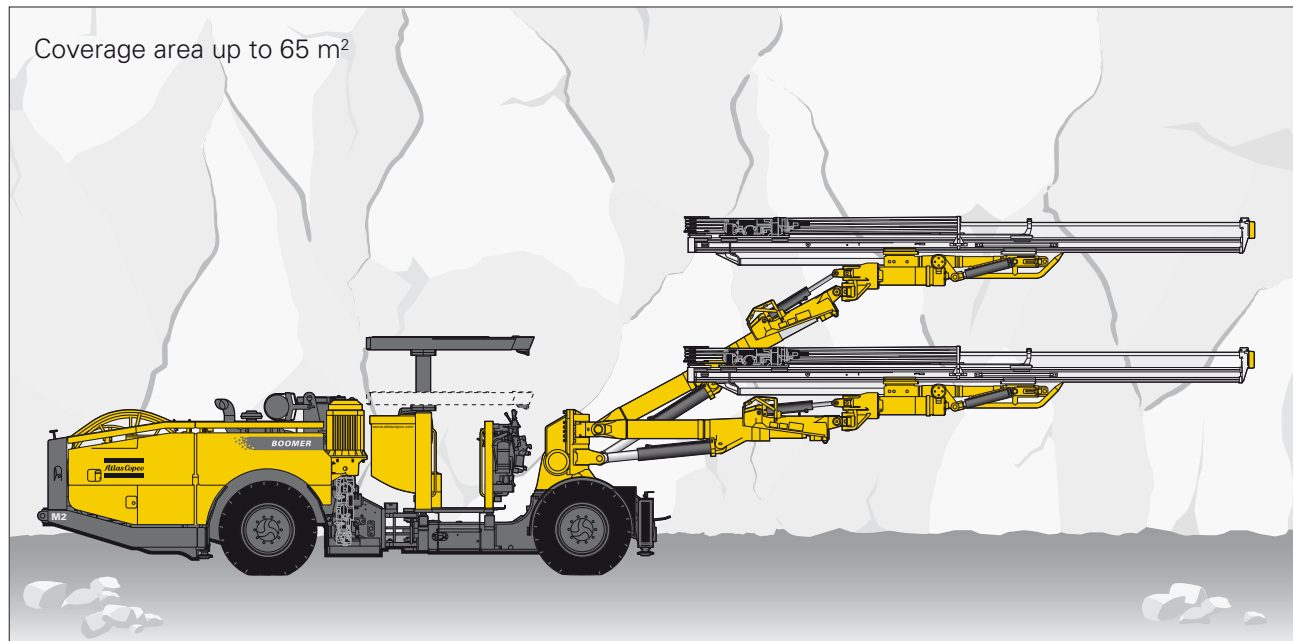

Hydraulically controlled mining and tunnelling face drilling rig with two BUT 35 SL booms. Available with a variety of rock drills to suit customer requirements.

Standard features

» Rock drill

- COP 1638, COP 1838ME or COP 2238 rock drill with dual-damping system for optimal consumable life
- Pressurized housing and mating surfaces to reduce internal contamination of the rock drill

» Hydraulic boom

- BUT 35 SL heavy-duty boom with double tripod suspension for accurate hydraulic parallel holding in all directions

» Hydraulic feed

- BMH 6000-series heavy-duty aluminium feed with high bending and torsional resistance for maximum durability
- Snap-on stainless steel sleeves and polymer contacts

» Control system

- Hydraulically controlled drilling system which incorporates the anti-jamming function Rotation Pressure Controlled Feed (RPCF)

» Carrier

- Sturdy, articulated carrier with four-wheel drive
- Powered by a 4-cylinder, EPA III/COM III (Tier 3/Stage IIIA) approved diesel engine
- Four jacks for stable set up

» General

- FOPS-approved telescopic protective roof
- Cable reel
- Hydraulically driven compressor
- Hydraulically driven water booster pump
- Working lights

Specifications

ROCK DRILL

	COP 1638	COP 1838ME	COP 2238
Shank adapter	R32/R38/T38	R32/R38/T38	R32/R38/T38
Height over drill centre	88 mm	88 mm	88 mm
Length without shank	1 008 mm	1 008 mm	1 008 mm
Impact power	16 kW	18 kW	22 kW
Impact rate	60 Hz	60 Hz	73 Hz
Hydraulic pressure	200 bar	230 bar	250 bar
Rotation system	Separate rotation	Separate rotation	Separate rotation
Rotation speed	0–340 rpm	0–340 rpm	0–340 rpm
Rotation torque, max	640 Nm	640 Nm	640 Nm
Lub. air consump. at 2 bar	6 l/s	6 l/s	6 l/s
Water consumption	1.1 l/s	1.1 l/s	1.1 l/s
Weight	170 kg	170 kg	170 kg
Sound level	<106 dB(A)	<106 dB(A)	<106 dB(A)

FEED

	BMH 6800	BMH 6812	BMH 6814	BMH 6816	BMH 6818
Total length	5 287 mm	5 582 mm	6 502 mm	7 102 mm	
Drill steel length	3 700 mm	4 310 mm	4 920 mm	5 530 mm	
Hole depth	3 443 mm	4 043 mm	4 668 mm	5 268 mm	
Weight, incl. drill	601 kg	631 kg	665 kg	696 kg	
Feed force	20.0 kN	20.0 kN	20.0 kN	20.0 kN	

» Boom

- BUT 35 SL
- Feed extension 1 800 mm
- Boom extension 1 600 mm
- Parallel holding complete
- Feed roll-over 360°
- Max. lifting angle +65°/–30°
- Max. swinging angle ±45°
- Weight, boom only 2 900 kg

» Air system

- Hydraulically driven screw compressor... Atlas Copco GAR 5
- Capacity, max at 9 bar 26 l/s
- Adjustable speed
- Air pressure gauge
- Hole blowing kit with 80 l air receiver

» Water system

- Hydraulically driven water booster pump.....Flygt PXR1607H
- Water booster pump max capacity at 15 bar 250 l/min
- Min water inlet pressure at 200 l/min, 2 bar
- Water pressure gauge
- Water flow guard

» Electrical system

- Total installed power 158 kW
- Main motors 2 x 75 kW
- Voltage 380–1 000 V
- Frequency 50–60 Hz
- Starting method star/delta (1 000 V direct start)
- Electronic overload protection for electric motors
- Percussion hour meter on operator display
- Digital voltmeter/amperage meter in electric cabinet
- Phase sequence indicator
- Earth fault indicator
- Battery charger
- Transformer 8 kVA
- Working lights, halogen 2 x 1 000 W
- Cable reel, diameter 1 600 mm
- Dual controls for cable reel

» Hydraulic system

- Hydraulic pumps 2 separate units, one for each boom
- Pumps unloaded at start
- System pressure, max 250 bar
- Hydraulic oil tank, volume max/min 250/200 l
- Low oil level indicator
- Oil temperature gauge on oil tank
- Electrical oil filling pump
- Oil filter indicator
- Water cooled oil
- Filtration 16 µm
- Mineral hydraulic oil
- Big hole drilling system

» Carrier

- Deutz 4-cylinder, TCD 2013 L04, EPA III/COM III (Tier 3/ Stage IIIA) approved 4-stroke prechamber diesel engine
- Power rating at 2 300 rpm 120 kW (160 hp)
- Torque at 1 600 rpm 618 Nm
- Articulated steering ±41° steering angle
- Fixed seat for tramming
- Four-wheel drive
- Hydrostatic power steering system
- Hydrodynamic transmission Clark 24000
- Front axle Dana 123/90
- Rear axle Dana 123/90, ±8° oscillation
- Automatic differential lock on front axle, limited slip
- Tyres 12.00 x R24
- Clearance outside axles 22° front, 13° rear
- Hydraulic jacks, front 2 extendable
- Hydraulic jacks, rear 2
- Service brakes 2 separate circuits
- Emergency and parking brakes SAHR
- Fuel tank, volume 100 l
- Exhaust catalyser
- Silencer
- Electric system 24 V
- Batteries 2 x 12 V, 125 Ah
- Tramming lights 8 x 70 W
- Working lights 2 x 1 000 W
- Brake lights
- Illuminated stairs for platform 2 x 70 W
- Fire extinguisher
- Central lubrication system
- Spirit level one for longitudinal, one for sideways
- Gradeability at max. load on drive wheels 1:4
- Horn, beacon and reverse alarm
- Shelf for drill bits and tools

Specifications

DRIFTER RODS

Dimension	Min. hole diameter
mm R38-HEX 35-R32	45
T38-HEX 35-R32	45
T38-HEX 35-R32 Speedrod	45
R38-HEX 35-SR35 Speedrod	45
T38-HEX 35-SR35 Speedrod	45
T38-HEX 35-SR35	45
T38-Rnd 39-SR35	45
T38-Rnd 39-R32	45
T38-HEX 35-R35	48
T38-HEX 35-R35 Speedrod	48
T38-Rnd 39-R35	48
T38-Rnd 39-SR35	48
T38-Rnd 38-R35 Speedrod	48
T38-Rnd 39-SR35 Speedrod	48

SHANK ADAPTERS

Thread	Diameter	Length
mm R38	38	435
T38	38	435
R32	38	525
T38*	38	525

**Intended for RAS and extension drilling with BSH 110*

COUPLINGS

Thread	Diameter	Length
mm R38	55	170
T38	55	190

EXTENSION RODS FOR INJECTION DRILLING/RAS

Dimension	Min. hole diameter
mm R32 Speedrod	51
T38 Speedrod	64

Optional equipment

» Rock drill/Drilling system

- Water mist flushing, external water and air supply
- Hole blowing kit
- External air supply connection for hole blowing kit

» Feed

- Telescopic feed BMHT 6000-series (max 18 ft)
- Extension drilling set BSH 110 (BMH feeds only)
- Feed prepared for RAS
- Rod Adding System, RAS
- Water spraying kit on cradle

» Boom

- Automatic boom lubrication kit, rear part of boom
- Feed angle measurement system, FAM 1
- Feed angle measurement system with hole depth measurement, FAM 2

» Protective roof

- Mounting height -80 mm/+60 mm/+310 mm
- Manual spotlight, left and/or right

» Cabin

- FOPS-approved cabin, noise level <80 dB(A), height 3 044 mm including:
 - Air conditioning unit
 - Fixed seat
 - CD-changer
 - Boot washing kit
- Cabin body made of stainless steel
- Front window, 24 mm
- Heating function for air conditioning (water transferred)
- Electrical heater, 1.2 kW, 230 V (CE)
- Joystick-controlled spotlights left and/or right

» Air system

- Compressor, GAR 30

» Water system

- Water hose reel

» Hydraulic system

- Biodegradable hydraulic oil
- Heater kit for hydraulic oil tank, diesel engine and electric motors

» Carrier

- Fire suppression system ANSUL (manual or Checkfire)
- Fire suppression system FORREX (manual or automatic)

» Electrical system

- Stainless steel electrical enclosure
- Electric cable type H07RN-F or Buflex
- Plug for cable
- Switch gear
- Electric outlet for accessories, 16 A (CE and not for 1 000 V)
- Extra transformer 3-phase, 15 kVA, 230/400 V

» Miscellaneous

- Hose/cable guiding at water/cable reel
- Hydraulic Swellex pump type HC1 for manual installation
- Manual lubrication kit
- Rig washing kit
- Boots washing arrangement
- Ni-Cr plated piston rods (limitations exist)

Measurements

SIDE VIEW

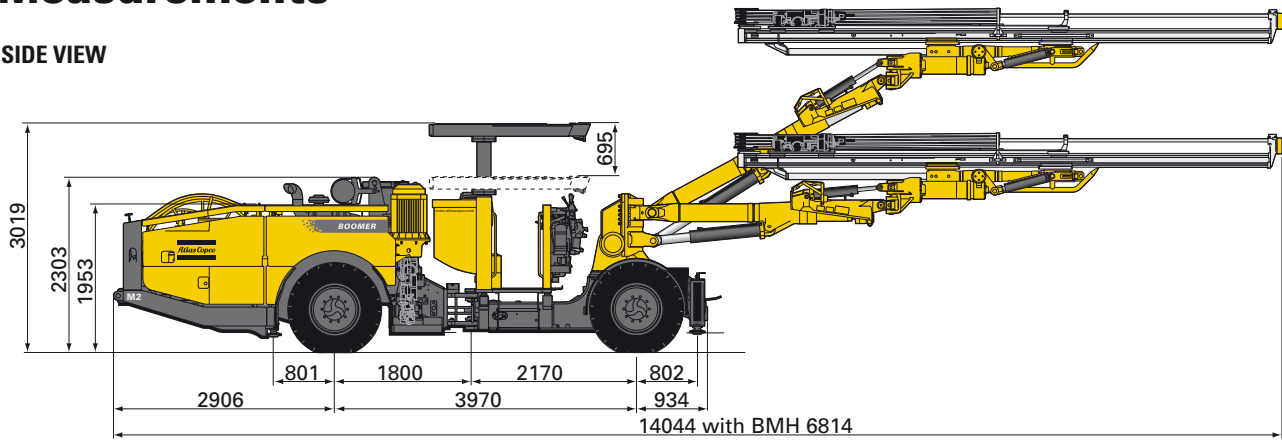

COVERAGE AREA

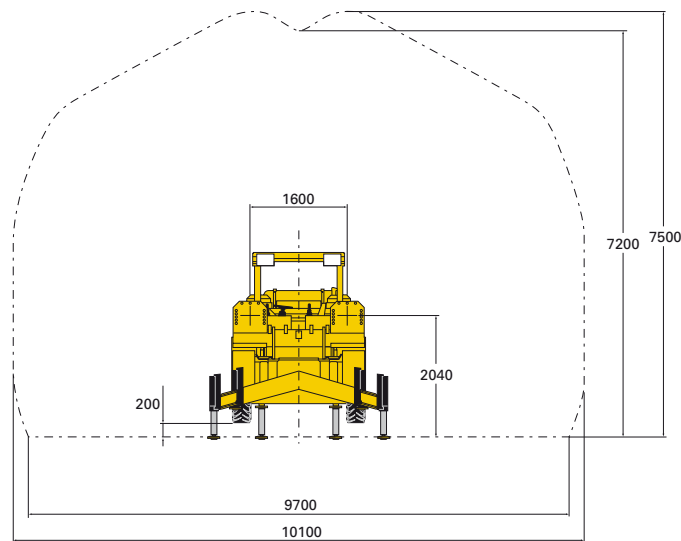

DIMENSIONS

mm		
	Width	2 245
	Height with cabin	3 044
	Height roof up/down	3 019/2 324
	Length with BMH 6814 feeds	14 044
	Ground clearance	215
	Turning radius outer/inner	7 200/4 400

TRAMMING SPEED

km/h		
	On flat ground (rolling resistance 0.05)	>14
	On incline 1:8	> 6

WEIGHT

gross weight, depending on configuration		
kg		
	Total	23 000–27 000
	Boom side	17 500–19 000
	Engine side	6 000–8 000

RECOMMENDED CABLE SIZE AND LENGTH

Voltage	Type	Dimension, mm ²	Diameter, mm	Length, m
380–400 V	H07RN-F	4X150	67	60
	Buflex	3x185+3G35	56	90
440–500 V	H07RN-F	4X120	60	75
	Buflex	3x150+3G25	52	100
550 V	H07RN-F	4X95	55	90
	Buflex	3x120+3G25	46	135
660–690V	H07RN-F	4X70	49	110
	Buflex	3x95+3G16	45	155
1,000 V	H07RN-F	N/A	N/A	N/A
	Buflex	3x50+3G10	33	200

Recommendations are given for surrounding temperature of 40 °C and up to a height of 2 000 m.